

PARTS LIST			
ITEM	QTY	PART NUMBER	DESCRIPTION
1	2	M6401014	Front/Rear Bezel
2	1	M6403314	Base/Internal Sides Sub-Assy
3	1	M6403414	Rear Panel - 1.5 mm thick
4	8	M3x8mm Pan	Rear Panel Screws
5	8	M4x16mm CSK	Bezel Assembly Screws
6	2	M3x6mm CSK	Base Panel Screws
7	8	M6420000	Clip for Trims
8	2	M6400050	Front Trim
9	2	M6400070	Rear Trim
10	1	M6402124	Wrap Around Cover
11	4	M6420104	Technofeet
12	2	AS055782	Bail Arm Kit
13	1	M6404224	Handle Bar

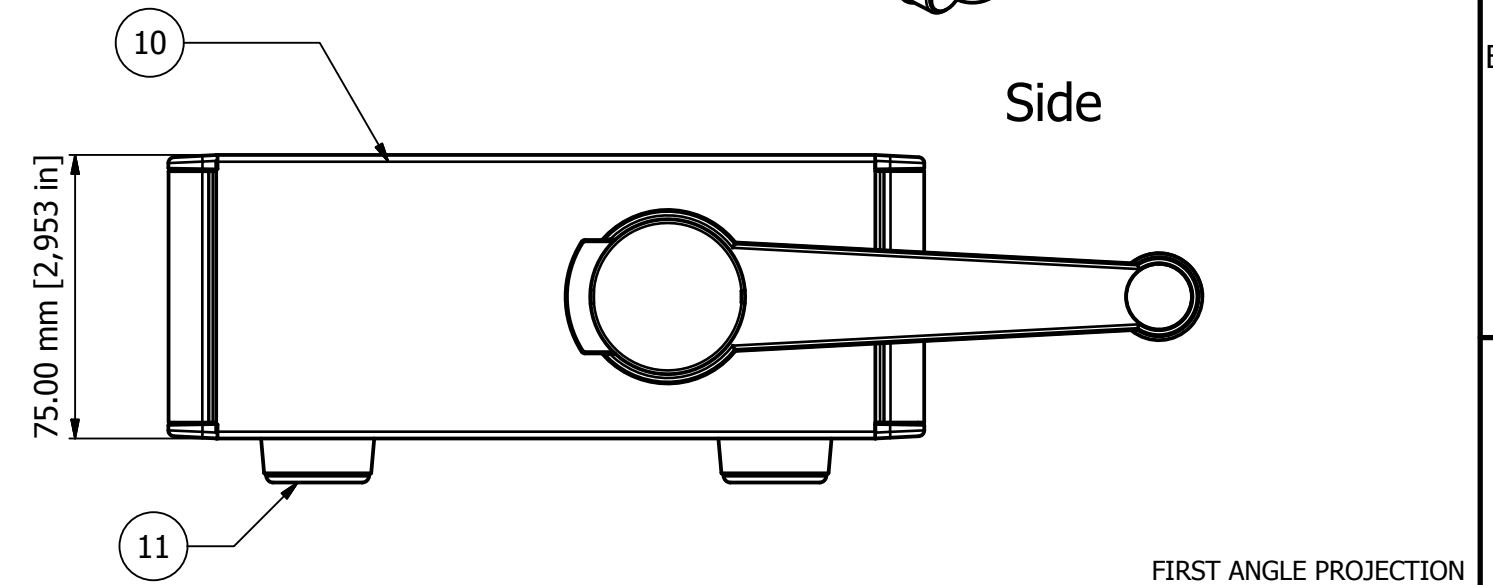
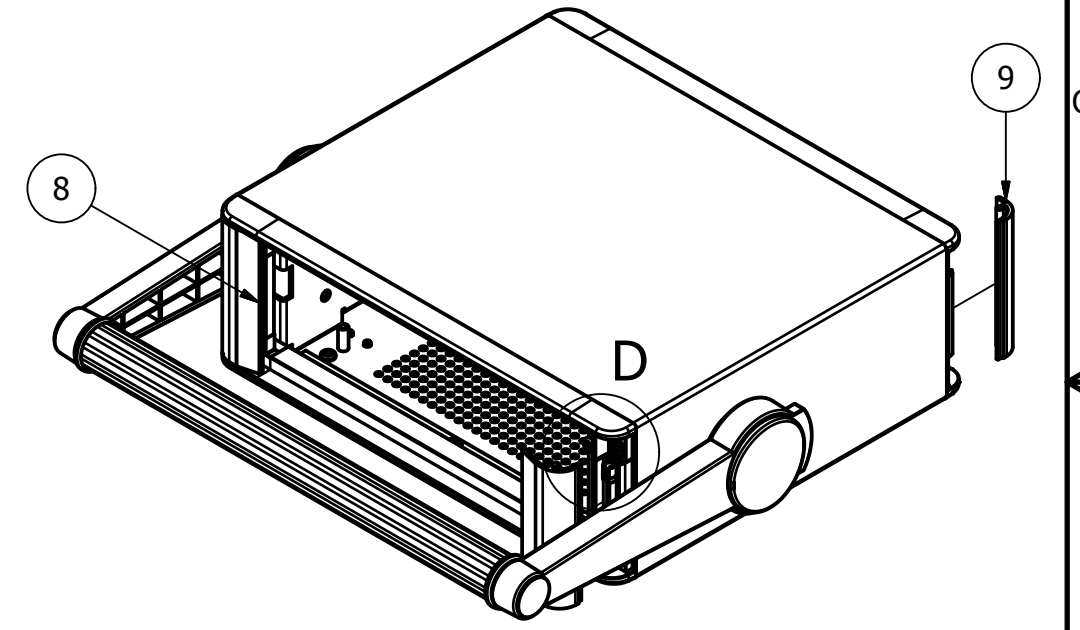

Front panel (M6400700) sold seperately

FIRST ANGLE PROJECTION

Designed by L Clark	Description Technomet R107H - Anthracite RAL 7016	Date 24/08/2016	Scale 1:2
<b>METCASE ENCLOSURES</b> 15 Brunel Way, Segensworth East, Fareham, Hampshire, PO15 5TX, UK. Tel: +44 (0)1489 583858 Email: metcase@okw.co.uk		<b>METcase™</b> www.metcase.com Part Number <b>M6422034</b>	
		Issue 1	Sheet 1 / 2

© OKW Enclosures Ltd (Date as shown). This drawing contains proprietary information of OKW Enclosures Ltd and is tendered subject to the following conditions. The information be retained in confidence, not be reproduced or copied, and not be used or incorporated in any product, unless permission is obtained in writing from OKW Enclosures Ltd.

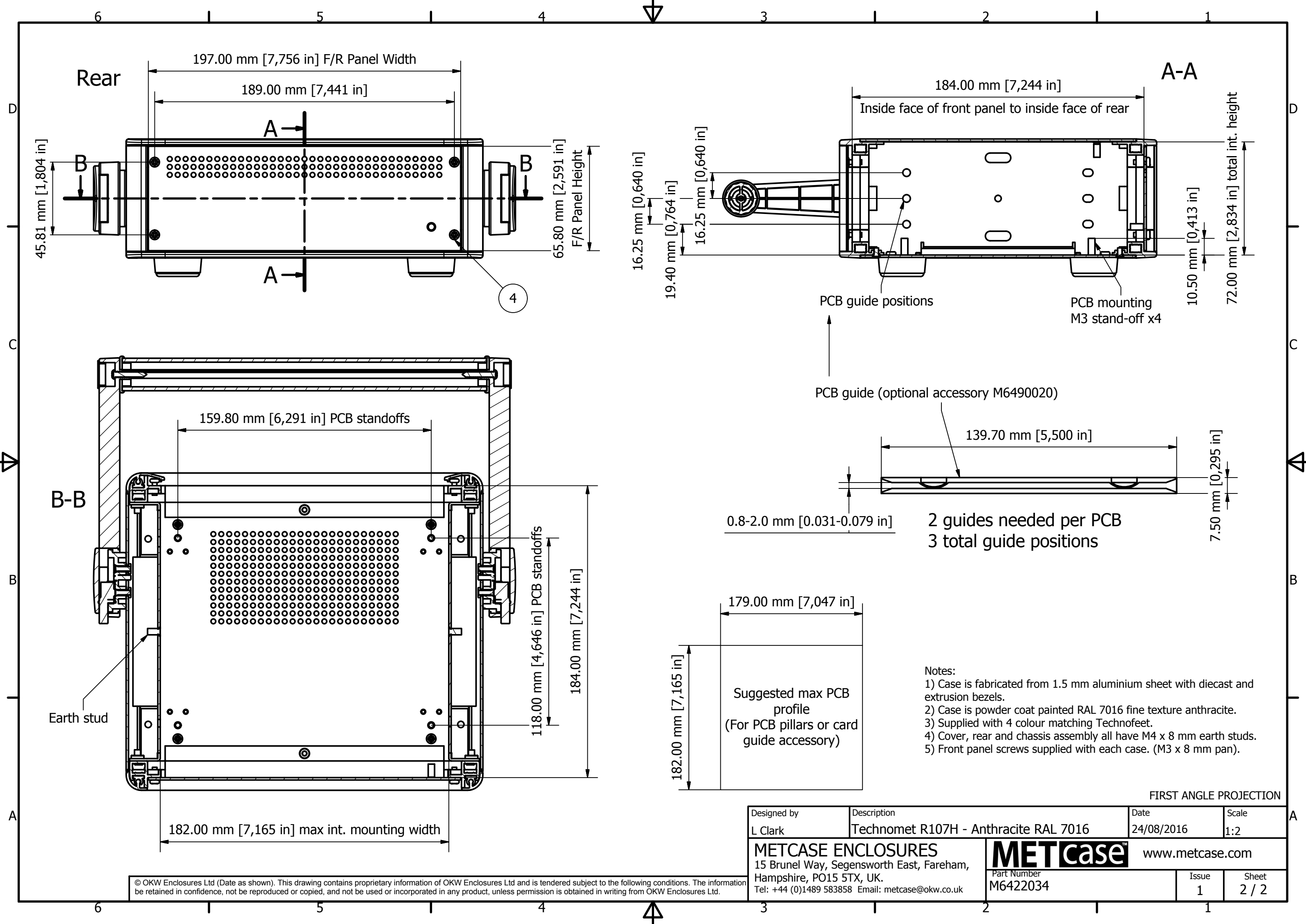

- Notes:
- 1) Case is fabricated from 1.5 mm aluminium sheet with diecast and extrusion bezels.
  - 2) Case is powder coat painted RAL 7016 fine texture anthracite.
  - 3) Supplied with 4 colour matching Technofeet.
  - 4) Cover, rear and chassis assembly all have M4 x 8 mm earth studs.
  - 5) Front panel screws supplied with each case. (M3 x 8 mm pan).

FIRST ANGLE PROJECTION

Designed by L Clark	Description Technomet R107H - Anthracite RAL 7016	Date 24/08/2016	Scale 1:2
<b>METCASE ENCLOSURES</b> 15 Brunel Way, Segensworth East, Fareham, Hampshire, PO15 5TX, UK. Tel: +44 (0)1489 583858 Email: metcase@okw.co.uk		<b>METcase™</b> www.metcase.com Part Number <b>M6422034</b>	
		Issue 1	Sheet 2 / 2

© OKW Enclosures Ltd (Date as shown). This drawing contains proprietary information of OKW Enclosures Ltd and is tendered subject to the following conditions. The information be retained in confidence, not be reproduced or copied, and not be used or incorporated in any product, unless permission is obtained in writing from OKW Enclosures Ltd.